

**Outline Dimension**

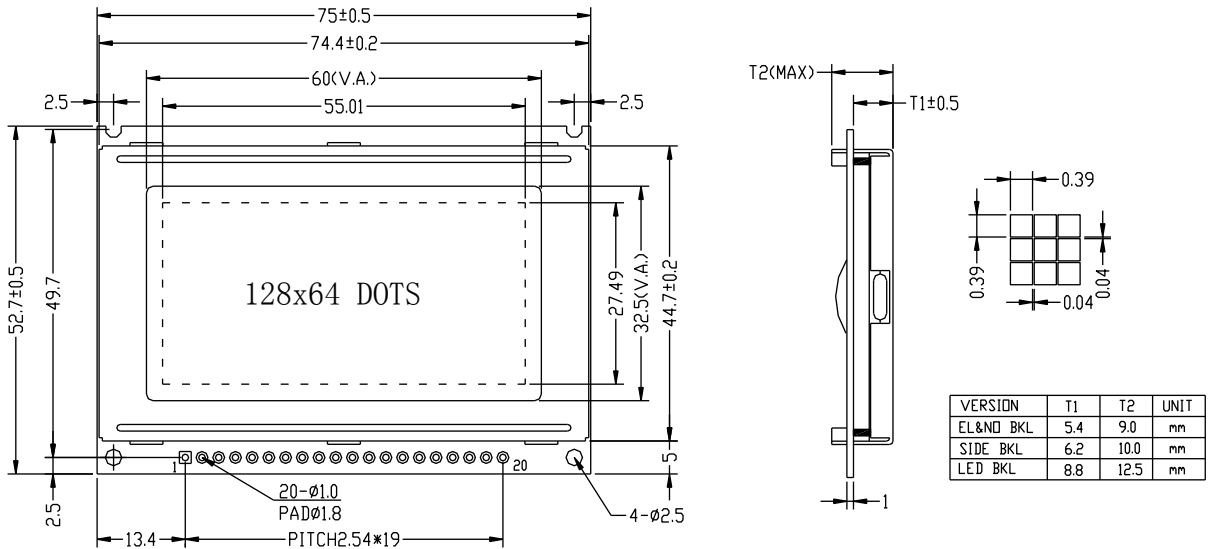

**Block diagram**

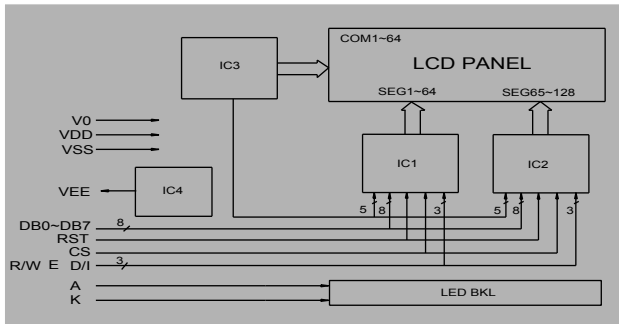

**Feature**

1. 128X64 dots graphic LCD module
2. Built-in controller (KS0108B)
3. 5.0V power supply
4. STN; 1/64 duty; LED B/L or EL B/L

**Mechanical Data**

Item	Standard	Unit
Module dimension	75.0x52.7	mm
Viewing area	60.0x32.5	mm
Dot size	0.39x0.39	mm
Dot pitch	0.43x0.43	mm

**Interface pin connections**

PIN NO	Symbol	Function
1	VDD	+5V
2	VSS	GND
3	V0	Constrast adjustment
4 to 11	DB0 to DB7	H/L Data bus line
12	CS1	Chip select for IC1
13	CS2	Chip select for IC2
14	RST	Reset signal
15	R/W	H/L Read/Write signal
16	D/I	H/L H: Data,L:Instruction code
17	E	H/L Enable signal
18	VEE	Negative voltage output
19	A	Power supply for BKL(4.2V)
20	K	Power supply for B/L(GND)

**Absolute Maximum Rating**

Item	Symbol	Standard			Unit
		Min	Typ	Max	
Power supply	VDD-VSS	-0.3	-----	5.5	V
Input voltage	VI	-0.3	-----	VDD	

**Electronical characteristics**

Item	Symbol	Condition	Standard			Unit
			Min	Typ	Max	
Input voltage	VDD	+5V	4.7	5.0	5.5	V
Supply current	I <sub>DD</sub>	VDD=5V	-----	8	-----	mA
Recommended LCD driving voltage for normal temp version module	VDD-V0	-20°C	-----	-----	-----	V
		0 °C	-----	9.8	-----	
		25°C	-----	9.5	-----	
		50°C	-----	9.3	-----	
LED forward voltage	V <sub>F</sub>	25°C	-----	4.2	4.5	V
LED forward current	I <sub>F</sub>	25°C	-----	240	-----	mA
EL power supply current	I <sub>EL</sub>	V <sub>EL</sub> =110V AC 400Hz	-----	-----	-----	mA