

Outline Dimension

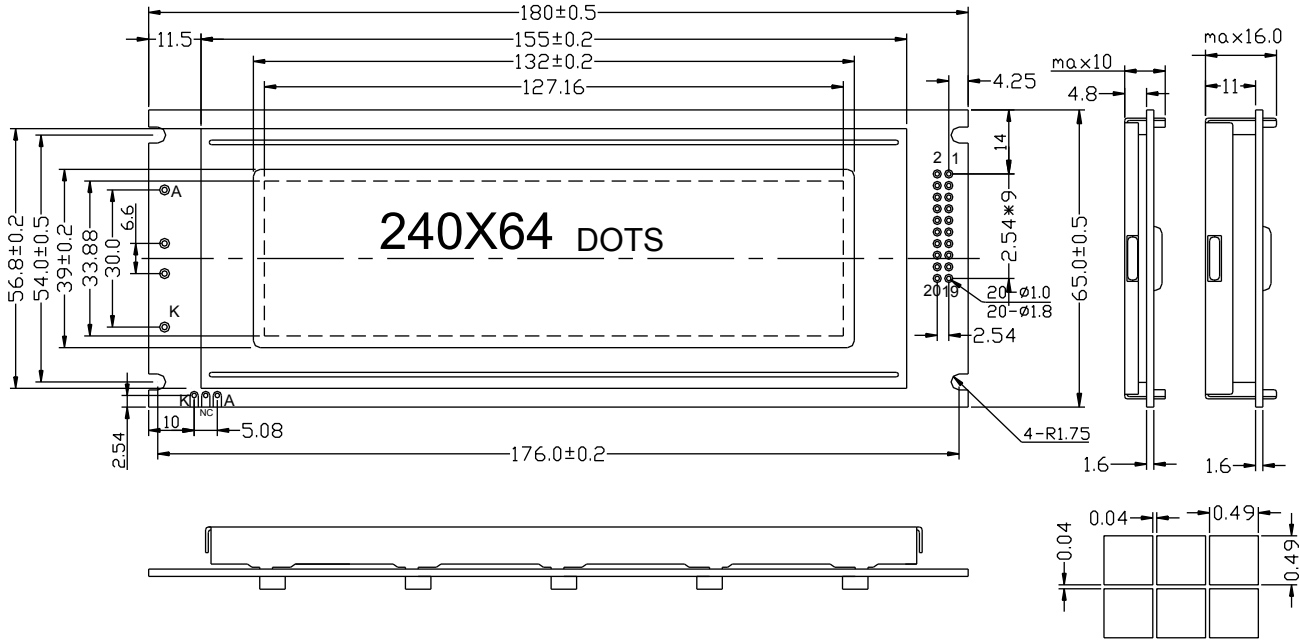

Block diagram

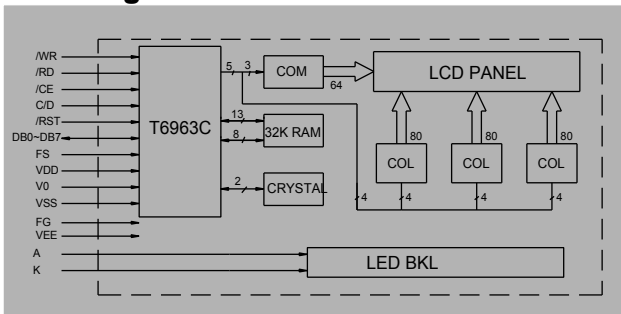

Feature

1. 240X64 dots graphic LCD module
2. Built-in controller (T6963C)
3. 5.0V power supply
4. STN; 1/64 duty; LED BKLor EL BKL

Mechanical Data

Item	Standard	Unit
Module dimension	180.0x65.0	mm
Viewing area	132.0x39.0	mm
Dot size	0.49x0.49	mm
Dot pitch	0.53x0.53	mm

Interface pin connections

PIN NO	Symbol	Function
1	FG	Frame ground
2	VSS	GND
3	VDD	+5V
4	V0	Constrast adjustment
5	/WR	Write enable signal
6	/RD	Read enable signal
7	/CE	Chip enable signal
8	C/D	H: Instruction,L: Data
9	VEE	Operating voltage for LCD
10	/RST	Reset signal
11 to 18	DB0 to DB7	Data bus line
19	FS	Font selection
20	N/A	NO Connection

Absolute Maximum Rating

Item	Symbol	Standard			Unit
		Min	Typ	Max	
Power supply	VDD-VSS	0.3	-----	5.5	V
Input voltage	VI	-0.3	-----	VDD	

Electronical characteristics

Item	Symbol	Condition	Standard			Unit
			Min	Typ	Max	
Input voltage	VDD	+5V	4.7	5.0	5.5	V
Supply current	I _{DD}	VDD=5V	-----	7.0	-----	mA
Recommended LCD driving voltage for normal temp version module	VDD-V0	-20°C	-----	-----	-----	V
		0 °C	-----	-----	-----	
		25°C	-----	12.6	-----	
		50°C	-----	-----	-----	
		70°C	-----	-----	-----	
LED forward voltage	V _F	25°C	-----	4.2	4.5	V
LED forward current	I _F	25°C	-----	350	-----	mA
EL power supply current	I _{EL}	V _{EL} =110V AC 400Hz	-----	-----	-----	mA